

Project Proposal

Magnetic Card Reader

28 February 2009
Michael Yasumoto

Project Abstract

This is a standard magnetic card reader as seen at Point Of Sale (POS) stations or security checkpoints. The commercial version would be a smaller standalone device or a module that is attached to a full workstation. Since this device is not meant to be portable, it is powered either directly from the workstation or in this case from the same power source as the microcontroller. It includes a 16x1 LCD screen that will possibly be upgraded later on to a more advanced screen. Also, a numeric keypad will be used to select which of the three tracks should be read from the magnetic card. If possible, a nixie tube will be added to display the current read mode.

Strategy

Description of the overall design: Above

What platform: based on the Zilog Z16 chip and development platform.

What capabilities: Lots of GPIO, timers, interrupts.

What external: numeric keypad, 16x1 LCD screen, 3-track magnetic card reader, nixie tube.

What sort of evaluations. There are several types of magnetic card readers (1, 2, or 3-track) with different types of interfaces (TTL, USB, PS2, RS232). I read the data sheet for the 3-track reader but the documentation is lacking so it might not be feasible. If this is the case then I will resort to using a 2-track reader. The nixie tube requires advanced hardware knowledge that I don't currently have so it will be added at the very end if there is time.

What software modules: LCD manager, numeric keypad manager, magnetic card reader manager, data parser for the three tracks of data read from magnetic card reader, possible nixie tube manager.

Main control loop. Design goal is to make an abstraction layer for all IO devices so that I am basically writing drivers for each component. This will make each hardware component modular so that I can easily add them to later projects once this class is finished.

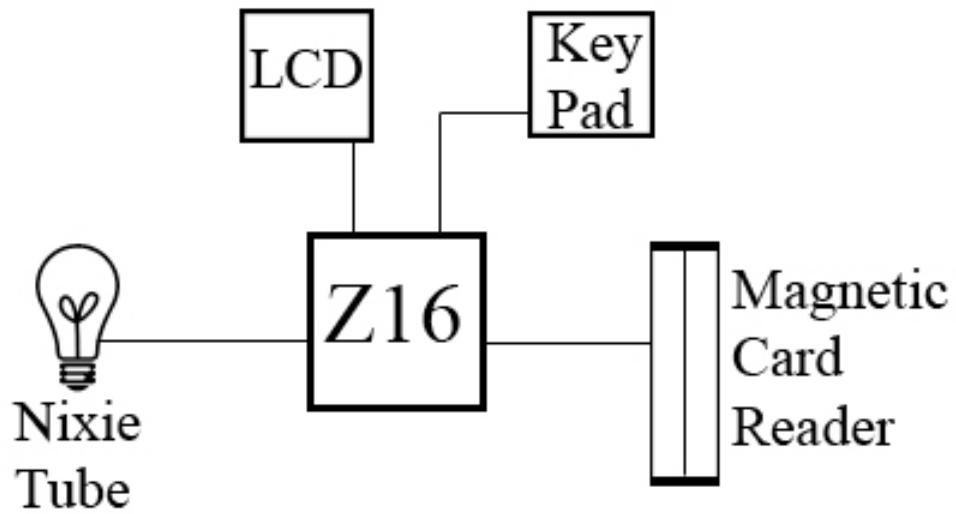

Preliminary hardware block diagram

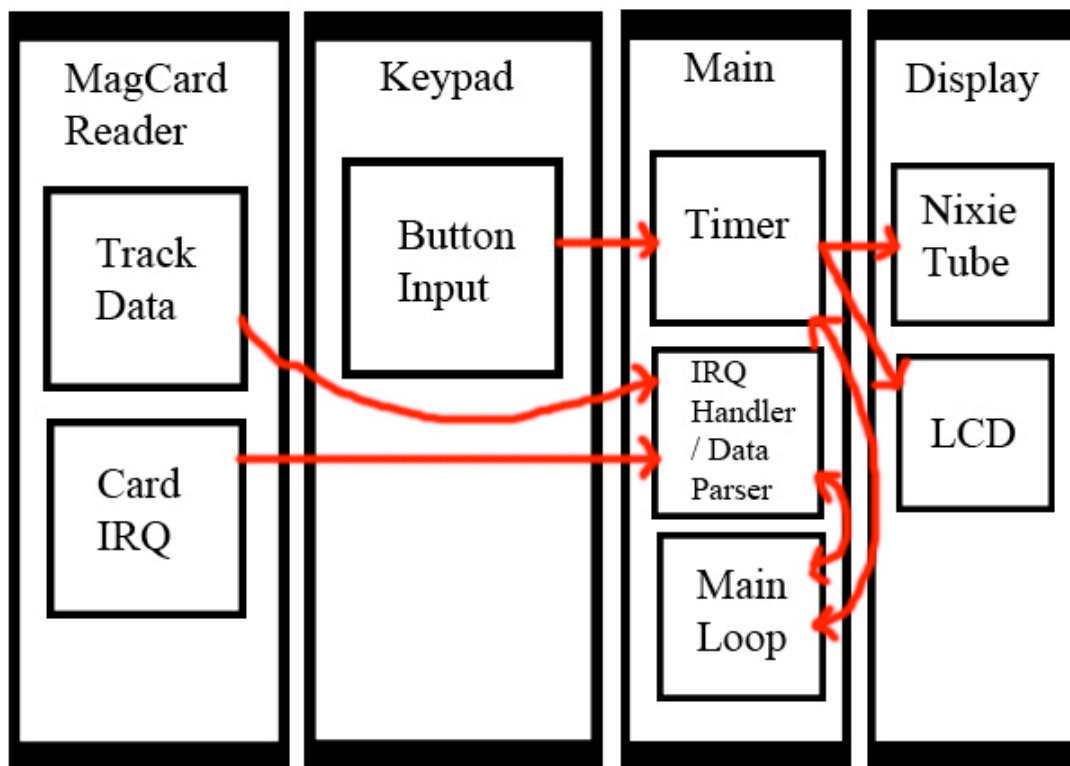

Preliminary software block diagram

Unknowns

The 3-track magnetic card reader is poorly documented so it may not work with the ZNEO. In class testing will determine if it is compatible. The main concern is whether it requires a clock that is faster than the 20Mhz limitation that the Z16 has.

The provided 16x1 LCD screen will work but if a more advanced screen is added later on, it is undetermined how or whether it will work.

The nixie tube may be complicated.

Implementation Plan

Use small Z16 kit.

Acquire all components (LCD, keypad, magcard reader, optional nixie tube and LCD).

Test 3-track reader and downgrade to the 2-track reader if it is incompatible

Magnetic Card Reader driver

Parser for the three tracks of card data

Display driver (LCD and possible optional LCD)

Keypad handler

Text display module (scrolls parsed card data).

Test app to verify abstraction layer for everything.

Add nixie tube if time

Resources

Z16 Kit (school provided)

Keypad (school provided)

16x1 LCD (school provided)

3-track card reader (already purchased)

2-track card reader (already purchased)

Nixie tube parts (need to buy)

Better LCD (need to buy)